

pH Safe 1

Neutralisation Cartridge



Safe, easy and Eco-friendly

The new innovative pH Safe neutralisation cartridge is patent pending. Capable of neutralising up to 800 litres (200 USgal) of acidic condensates at pH3, the pH Safe 1 has been specifically designed to treat condensates produced by gas condensing boilers. The pH Safe simply slots into the Si-82 condensate removal pump.

BENEFITS

- **Preserve the plumbing system and the environment**
 - prevents damages on concrete and plastics
 - prevents corrosion on metal parts.
 - respects the environment
- **Easy to install**
 - easy to install and replace, **quick fit cartridge** slots inside the pump inlet
 - **no limestone sludge** build up
 - no dead volume of sulphuric acid
 - compact design suitable for both floor and wall mounted boilers
- **Constant efficiency**
 - Sludge is permanently evacuated through the pump and the **neutralisation capacity remains constant**.
 - **Treatment** of the concentrated acid is **immediate**. No dilution from standing water inside the tank
- **Replacement made easy**

The **transparent cartridge** and identification label indicates when the cartridge should be changed.
- **Siphon trap**

The neutralisation cartridge slots inside the pump and sits below the drain water level. This creates a permanent siphon trap that limits the amount of acidic fumes escaping inside the property.

KIT CONTENTS



- Neutralisation cartridge
- Maintenance indication label

APPLICATIONS

For use with any Gas Condensing Boilers :

- up to 25kW if pH > 3.0 & qty < 800l (200 USgal)
 - up to 50kW if pH > 3.5 & qty < 1600l (400 USgal)
- based on a 12 months replacement program



TECHNICAL SPECIFICATION

Max. condensate acidity	pH > 3.0 (Gas condensing boilers)
Max. condensate volume	800 liters (200 USgal)
Pump compatibility	Si-82 range, SI1800 range
Max. boiler capacity (can be more depending on actual pH level and condensate volume)	25kW
Estimated replacement period (can be more depending on actual pH level and condensate volume)	12 months
Inlet tube diameter	Øext 15-17mm (OD 19/32" – 5/8")
Max. condensate temperature	65°C (80°C – 1 min) 150°F (176°F – 1 min)
Safety standards	CE
RoHS directive	Compliant
WEEE directive	Compliant
Treatment product Weight	0.100 kg (0.22 lb)
Weight (including box)	0.130 kg (0.29 lb)
Cartridge	L 151 x Øext 29.5mm Inlet Øext 17mm (OD 5/8")
Packaging	1 pc (L 42 x W 40 x H 170 mm) (L 1"21/32 x W 1"9/16 x H 6"11/16)
Master Pack	15 pc (L 215 x W 135 x H 180 mm) – 2.0kg (L 8"15/32 x W 5"5/16 x H 7"1/16) – 4.4lb
Pallet quantity	1875 pieces (EUR size) – 250kg (550lb)

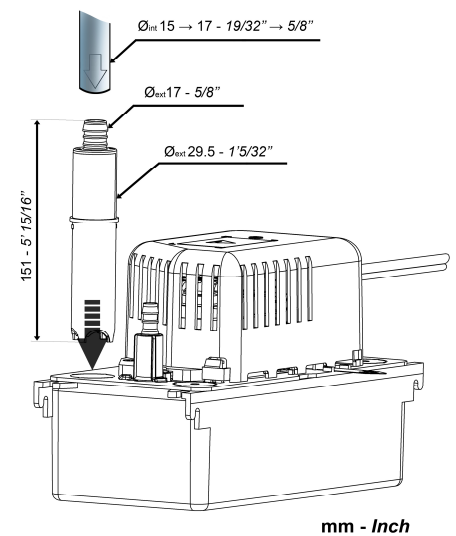

ESTIMATED REPLACEMENT PERIOD (months)

Condensate pH	Condensate Qty	25kW boiler	35kW boiler	50kW boiler
>3.0	<800 l (200 USgal)	12	8	6
>3.5	<1600 l (400 USgal)	24	16	12
>4.0	<3200 l (800 USgal)	48	32	24

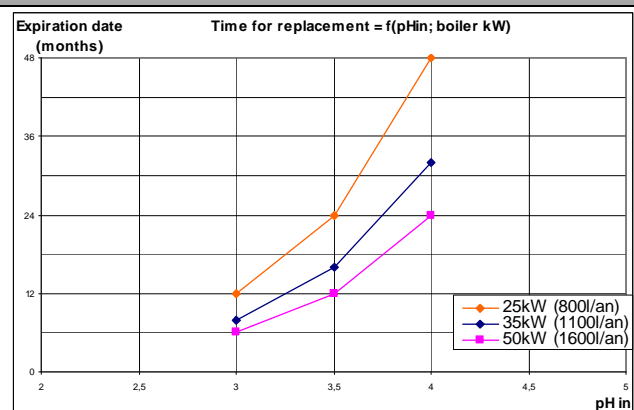

RECOMMENDED ACCESSORIES



ACC00224
Adapter Øext 15-17-24-25mm
(OD 19/32" – 5/8" – 1")



ACC02040
Adapter Øext 24-25-32-40mm
(OD 1" – 1"1/4 – 1"1/2)